

Assembly instructions VOSS quick connect system 250

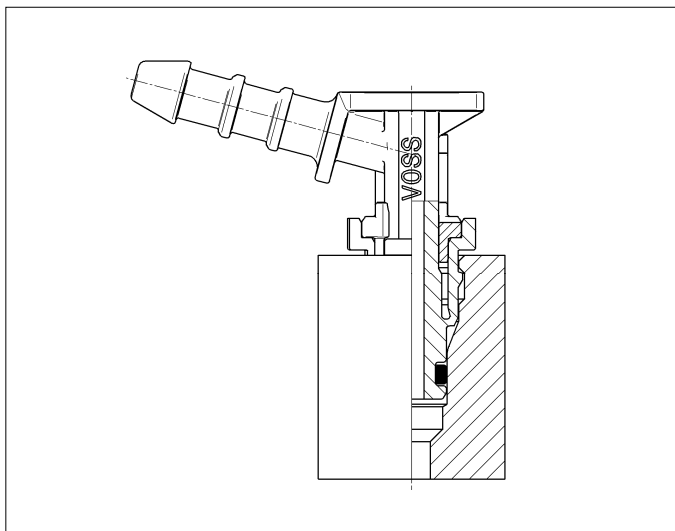

Fig. 1: VOSS quick connect system 250

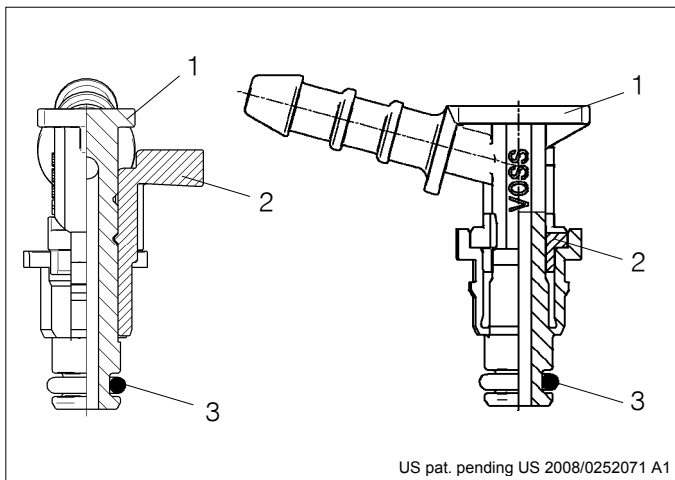

Fig. 2: Single components

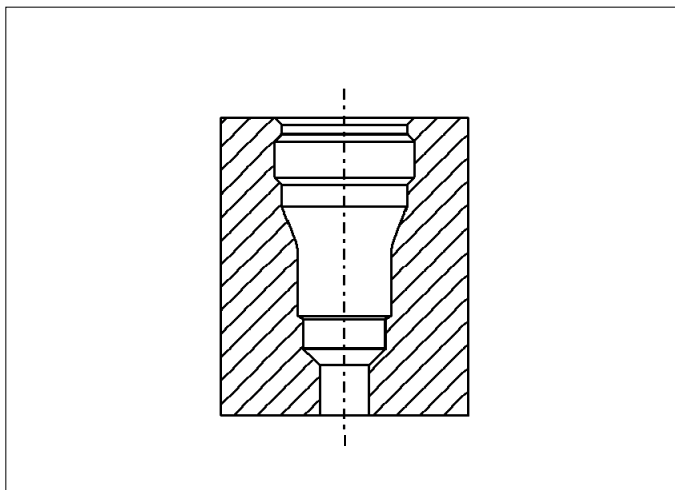

Fig. 3: Connecting port

These assembly instructions are intended for qualified fitters of fuel systems in automotive engineering.

1. Range of application

The VOSS quick connect system 250 (fig. 1) is designed for diesel fuel according to DIN EN 590.

Depending on operating conditions, the system is applicable at negative pressure and at a positive pressure of up to 5 bar.

Quick connect system 250 is designed for a temperature range between -40°C and $+120^{\circ}\text{C}$.

Applications for other media, temperatures and pressure ranges on request.

2. Single components

VOSS quick connect system 250 is composed of (fig. 2):

- 1 Elbow plug
- 2 Locking element (shown in the locked position)
- 3 O-ring

Other designs are possible.

The plug is suitable for the connection of hoses. The connection of polyamide tubes requires a different fir-tree profile.

VOSS quick connect system 250 requires a connecting port at the component according to fig. 3 or an adequate adapter.

A specification of the connecting port can be provided if required.

The connecting port should preferably be made of brass or steel.

3. Functional description

The function of VOSS quick connect system 250 is provided by inserting the plug into the connecting port, while paying attention to the assembly instructions.

Pressing down the locking element serves as an additional locking of the connection.

4. Assembly instructions

4.1. Assembly

Before inserting the plug, check the connecting port and the adapter respectively, paying particular attention to its bore-hole. The connection must be clean and should not show any signs of damage.

The assembly has to be carried out at room temperature ($23^{\circ}\text{C} \pm 5^{\circ}\text{C}$).

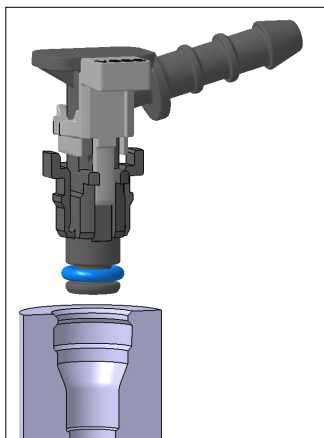

Fig. 4: Plug and port in the initial position

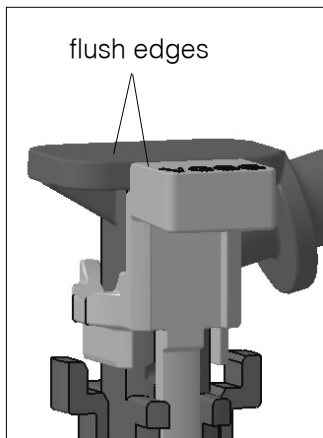

Fig. 5: The locking element is flush with the plug's top edge

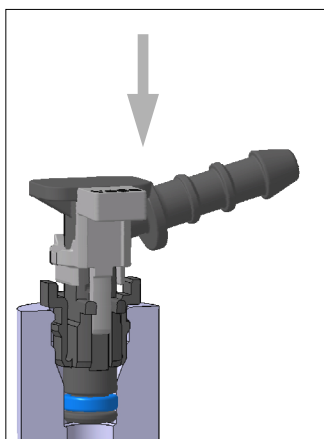

Fig. 6: Pushing the plug into the connecting port

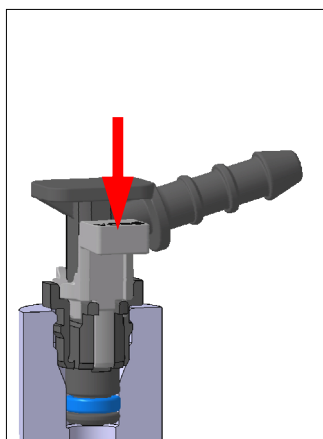

Fig. 7: Locking the plug

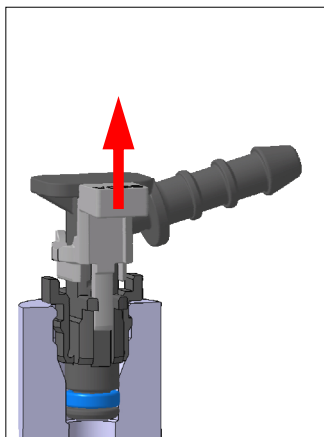

Fig. 8: Unlocking the plug for disassembly

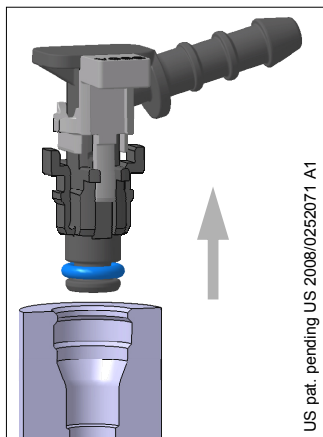

Fig. 9: Pulling the plug out of the connecting port

While inserting the plug, the locking element has to be flush with the plug's top edge (locking element not pressed down, figs. 4, 5).

The plug has to be pushed down to the limit stop of plug collar into the bore-hole of the connecting port (fig. 6).

Pressing down the locking element secures the connection (fig. 7).

4.2. Disassembly

The fuel line must be free of any pressure before disconnecting.

For disassembly the locking element has to be pulled up (fig. 8).

Now the plug can be pulled off the connecting port (fig. 9).

4.3. Reassembly

Before reassembly the system has to be checked for completeness and sound condition (especially the O-ring). Damaged components must be replaced.

All single components must be cleaned before reassembly. The connecting port must be checked for cleanliness.

Then the plug has to be pushed into the connecting port with a newly greased O-ring.

4.4. Replacing the O-ring

The damaged O-ring has to be removed. The groove must be cleaned accurately. Then a new greased O-ring can be mounted. All damage, excess stretching or twisting of the O-ring has to be avoided.

4.5. Greasing the O-ring

In order to ensure the functional reliability of the O-rings, only grease that has been tested and approved by VOSS may be used.

Approved lubricating grease: Bechem Berulub Hydrohaf GR

US pat. pending US 2008/0252071 A1